

- EN** Quick start guide
- DE** Schnell-Start-Anleitung
- FR** Guide d'installation rapide
- NL** Snelstart gids
- IT** Guida introduttiva
- ES** Guia de inicio rápido
- PT** Guia de início rápido
- NO** Hurtigguide
- SV** Snabbguide
- PL** Szybkie wprowadzenie
- ZH** 快速入門指南
- AR** عيبرسلا ءدبلا ليلد
- RU** Краткое руководство по эксплуатации

## B-Compact

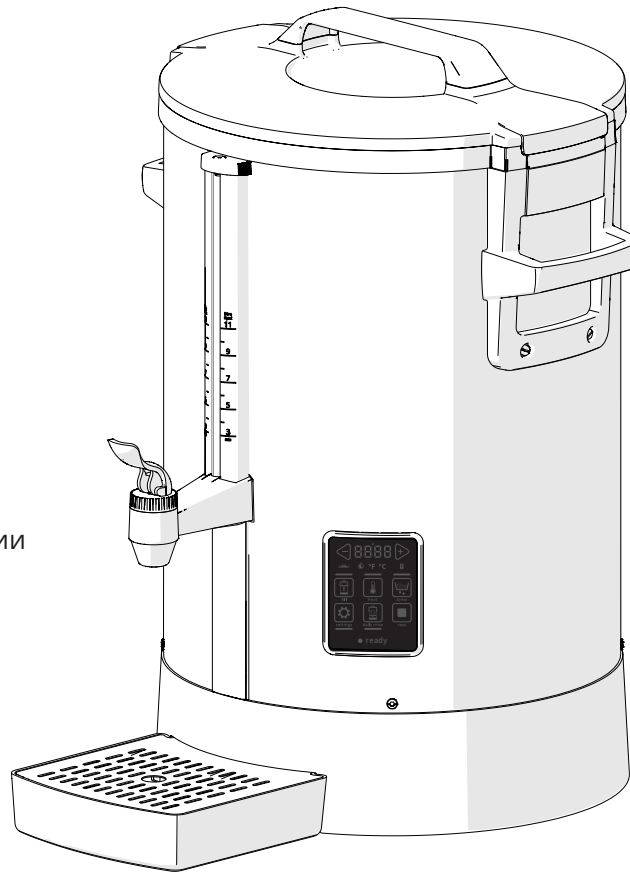

**Model-no:**

- MB-001
- MB-002

**700.403.918 C**

pictograms | Piktogramme | pictogrammes | pictogrammen | pittogrammi | pictogramas | pictogramas | piktogrammer | piktogram | piktogramy | 象形圖 |  
پيكتوگراممى | هيحيضوتلا زومرلا



online manual | Online-Handbuch | manuel en ligne | online handleiding | manuale online | manual en línea | manual online | online-håndbok |  
bruksanvisning online | instrukcja obsługi online | 線上手冊 | تڤرتن إال ربع مادختس إال ليد | онлайн-руководство



install | Installation | installation | installeren | installare | instalar | instalação | installer | installera | instalacja | 安裝 | تيبثتلا | установка



device overview | Geräteübersicht | aperçu de l'appareil | overzicht van het apparaat | panoramica del dispositivo | resumen del dispositivo |  
visão geral do dispositivo | oversikt over enheten | översikt över enheten | przegląd urządzenia | 裝置概覽 | زاہجلا ىلع فام ترظن | обзор устройства



user interface | Benutzeroberfläche | interface utilisateur | gebruikersinterface | interfaccia utente | interfaccia utente | interface do utilizador | brukergrensesnitt |  
användargränssnitt | interfejs użytkownika | 使用者介面 | مدختس إال هجاو | пользовательский интерфейс



daily cleaning | tägliche Reinigung | nettoyage quotidien | dagelijks reinigen | pulizia quotidiana | limpieza diaria | limpeza diária | daglig rengjøring |  
daglig städning | codzienne czyszczenie | 每日清潔 | يوميا فيظنتلا | ежедневная чистка



weekly cleaning | wöchentliche Reinigung | nettoyage hebdomadaire | wekelijks schoonmaken | pulizia settimanale | limpieza semanal | limpeza semanal |  
ukentlig rengjøring | veckovis rengöring | cotygodniowe czyszczenie | 每週清潔 | يعوبس إال فيظنتلا | еженедельная чистка



damp cloth | feuchtes Tuch | chiffon humide | vochtige doek | panno inumidito | paño húmedo | pano húmido | fuktig klut | fuktig trasa | wilgotna szmatka |  
濕布 | ظللم شامق ةعطق | влажная ткань



dishwasher | Spülmaschine | lave-vaisselle | vaatwasser | lavastoviglie | lavavajillas | máquina de lavar louça | oppvaskmaskin | diskmaskin |  
zmywarka do naczyń | 洗碗機 | قابطال ؤلاسغ | посудомоечная машина



optional | optional | facultatif | optioneel | facoltativo | opcional | opcional | valgfritt | valfritt | opcjonalny | 可選 | ىرايخا | необязательный



dish soap | Reinigungsmittel | détergent de lave-vaisselle | afwasmiddel | sapone per piatti | detergente para platos | detergente para louça | oppvaskmiddel |  
diskmedel | mycie ręczne | 洗碗精 | قابطال نوباص | средство для мытья посуды



rinse thoroughly | gründlich spülen | rincer soigneusement | grondig afspoelen | sciacquare accuratamente | aclarar bien | enxaguar bem | skyll grundig |  
skölj ordentligt | dokładne splukanie | 洗碗精 | اديج فطشا | тщательно промыть



press button 1x | Taste 1x drücken | appuyer 1x sur le bouton | druk 1x op de knop | premere 1x il tasto | pulse el botón 1x | pressionar o botão 1x |  
trykk 1x på knappen | tryck 1x på knappen | naciśnij przycisk 1x | 按一下按鈕 | ندحاو قرم رزلا ىلع طغضا | нажать кнопку 1x



press + hold button | Taste drücken + halten | appuyer sur le bouton + le maintenir enfoncé | druk en houd knop ingedrukt | Premere e tenere premuto il pulsante |  
mantenga pulsado el botón | pressionar e manter pressionado o botão | trykk og hold knappen inne | tryck knappen och håll den intryckt | naciśnij i przytrzymaj  
przycisk | 按住按鈕不放 | رزلا ىلع رارمستس إال عم طغضا | нажать и удерживать кнопку

scan QR code | QR-Code scannen | scanner code QR | scan QR-code | cansione codice QR | escanear código QR | digitalizar código QR | skann QR-koden | skanna QR-kod | zeskanuj kod QR | 掃描 QR 碼 | ةعيرسلا قباجتسال زمر حسم | сканировать QR-код



safety book | Sicherheitsbuch | manuel de sécurité | veiligheidsboek | prontuario per la sicurezza | manual de seguridad | livro de segurança | sikkerhetsbok | säkerhetsbok | instrukcja bezpieczeństwa | 安全手冊 | قماالسل باتك | книга по безопасности



700.403.347 (STD)

700.403.769 (AR FA)

700.403.713 (NA)

700.403.839 (JA KO ZH)



parts | Teile | pièces | onderdelen | parti | piezas | peças | deler | delar | części | 零件 | أجزاء | детали

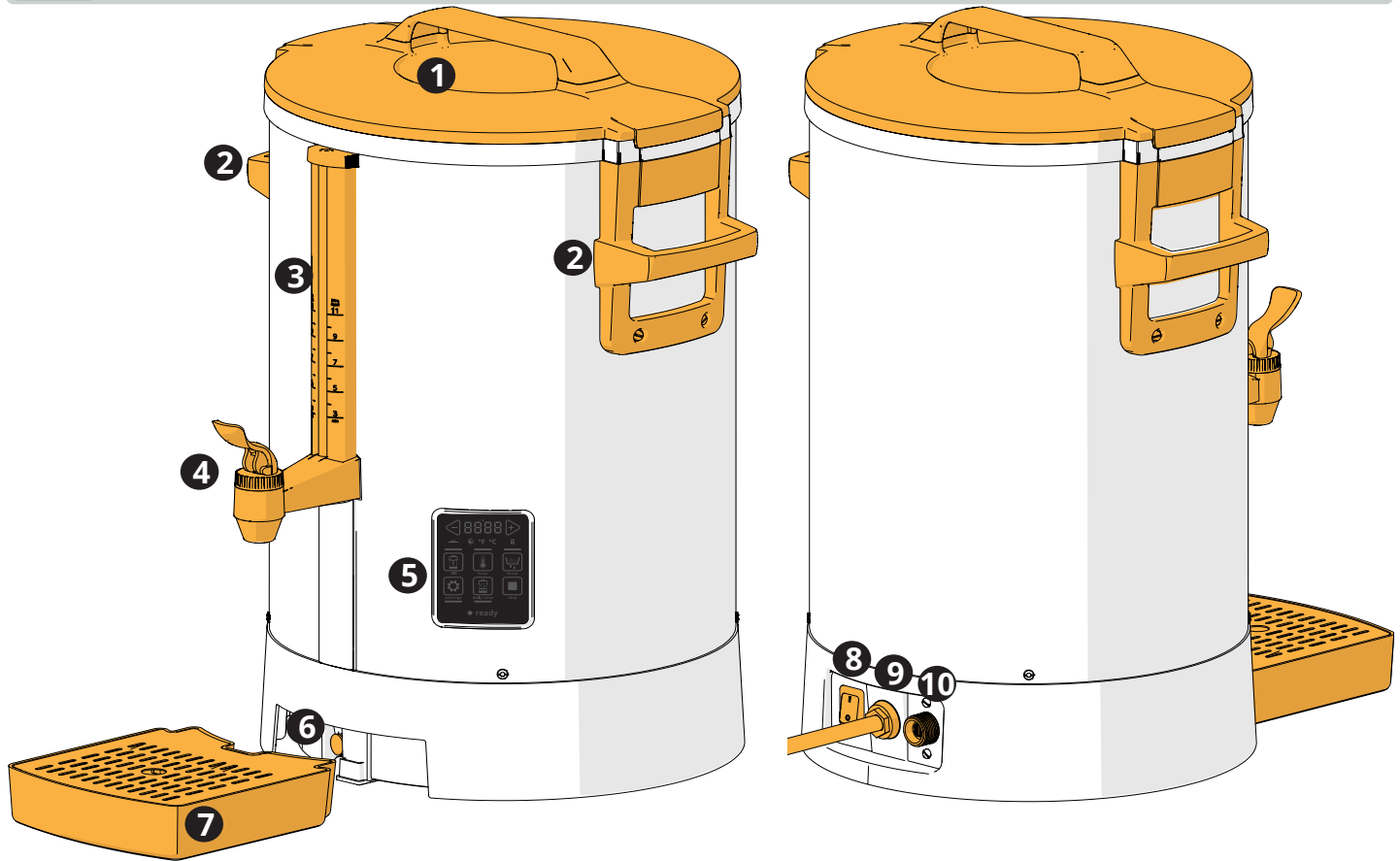

- 
- 1** lid | Deckel | couvercle | deksel | coperchio | tapa | tampa | lokk | lock | pokrywka | 蓋子 | ءاطغ | крышка
- 
- 2** handle | Handgriff | poignée | hendel | impugnatura | asa | pega | håndtak | handtag | uchwył | 手柄 | ضربقم | ручка
- 
- 3** gauge glass | Schauglas | verre de jauge | peilglas | vetro dell'indicatore | salida de jarra | visor | væskestandsglass | synglas | wylot pojemnika | 觀察窗 | ضربق ءنذفان | смотровое стекло
- 
- 4** tap | Zapfhahn | robinet | grifo de vaciado | kraan | rubinetto | torneira | kran | kran | kran spustowy | 龍頭 | روبنص | кран
- 
- 5** user interface | Benutzerschnittstelle | interface utilisateur | gebruikersinterface | interfaccia utente | panel de control | interface do utilizador | brukergrensesnitt | användargränssnitt | schemat budowy panelu sterowania | 使用者介面 | مدختم سمل ءه جاو | пользовательский интерфейс
- 
- 6** drain hose | Ablaufschlauch | tuyau de vidange | afvoerslang | tubo di drenaggio | manguera de drenaje | mangueira de drenagem | avløpslange | dräneringsslang | wąż spustowy | 排水軟管 | فيرصت موطرخ | сливной шланг
- 
- 7** drip tray | Tropfschale | collecteur | lekbak | vassoio raccogliacqua | bandeja de goteo | bandeja coletora | spillbrett | spillbricka | taca ociekowa | 滴水盤 | ريطق ءضوح | капельница
- 
- 8** on/off switch | Ein-/Aus-Schalter | interrupteur marche/arrêt | aan/uit-schakelaar | interruttore acceso/spento | interruptor de encendido/apagado | interruptor liga/desliga | på/av-bryter | strömbrytare | przełącznik wł./wyl. | 開關 | فاق يال غشمت حاتفم | ыключатель
- 
- 9** electrical connection | elektrischer Anschluss | connexion électrique | elektrische aansluiting | connessione di alimentazione elettrica | conexión eléctrica | ligação elétrica | elektrisk tilkobling | elektrisk anslutning | kabel elektryczny | 電源連接 | يئابرمك ليصوت | электрическое подключение
- 
- 10** water connection | Wasseranschluss | connexion d'eau | wateraansluiting | connessione di alimentazione idrica | conexión de agua | ligação de água | vanntilkobling | vattenanslutning | przyłącze wody | 水源連接 | مايم ليصوت | подключение к водопроводу
-



basic buttons | wesentliche Tasten | boutons basiques | basisknoppen | pulsanti di base | botones básicos | botões básicos |  
grunnleggende knapper | basknappar | podstawowe przyciski | 基本按鈕 | عيساس آل رارز آل | основные кнопки



adjust value | Wert einstellen | ajuster valeur | de waarde afstellen | regolare il valore | ajustar valor | ajustar valor | juster verdi | justera värde |  
zmień wartość | 調整數值 | تميقال طبض | настроить значение



fill | füllen | remplir | vullen | riempire | llenar | encher | fülle | fylla | napelnienie | 注水 | علم | заполнить



heat up | erhitzen | chauffer | verwarmen | riscaldare | calentar | aquecer | varme opp | uppvärmning | napelnienie | 加熱 | ني خست | нагреть



brew | brühen | préparer du café | koffie zetten | infondere | preparación del café | preparar | brygge | rengöra | przygotowanie kawy | 冲煮 |  
ريضحت | заварить



settings | Einstellungen | paramètres | instellingen | impostazioni | ajustes | configurações | innstillinger | inställningar | ustawienia | 設定 |  
اتاداعإل | настройки



daily rinsing | tägliche Spülung | rinçage quotidien | dagelijks spoelen | risciacquo giornaliero | aclarado diario | enxaguamento diário | daglig skylling |  
daglig sköljning | codzienne płukanie | 每日冲洗 | يموي فطش | еждневное ополаскивание



cancel | abbrechen | annuler | stoppen | arresto | cancelar | cancelar | stopp | stopp | anuluj | 取消 | اءغل | отмена



indicatore | Indikatoren | indicateurs | indicatori | indicadores | indicadores | indikatorer | Indikatorer | wskaźniki | 指示器 |  
تارشؤملا | индикаторы



place lid | Deckel aufsetzen | placer couvercle | deksel plaatsen | collocare il coperchio | colocar tapa | colocar a tampa | sett på plass lokket |  
sätt på lock | umieść pokrywę | 盖板已放置 | اءاطغلا عضو | установите крышку



time | Zeit | temps | tijd | tempo | tiempo | tempo | tid | tid | czas | 時間 | تقولا | время



temperature unit | Temperatureinheit | unité de température | temperatuureenheid | unità di temperatura | unidad de temperatura |  
unidade de temperatura | temperaturenhet | temperaturenhet | jednostka temperatury | 温度单位 | فزارحل ءجرد تدحو |  
единица измерения температуры



lock | sperren | serrure | vergrendeling | blocco | cierre | bloqueio | låse | lås | blokada | 鎖定 | لفق | блокировка



device status 'on' | Gerätestatus 'ein' | état de l'appareil 'marche' | apparaatstatus 'aan' | stato del dispositivo 'attivo' | estado del dispositivo 'encendido' |  
estado do dispositivo «ligado» | enhetsstatus 'på' | enhetens status 'på' | status urządzenia 'włączony' | 裝置狀態 '開啟' | ٲلي غشت " زاءجلا قلا ح |  
состояние устройства «включено»



device | Gerät | dispositif | apparaat | dispositivo | dispositivo | dispositivo | enhet | enhet | urządzenie | 装置 | زاهج | устройство

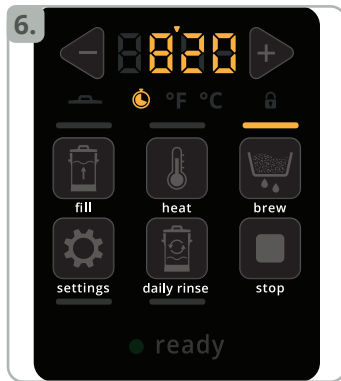
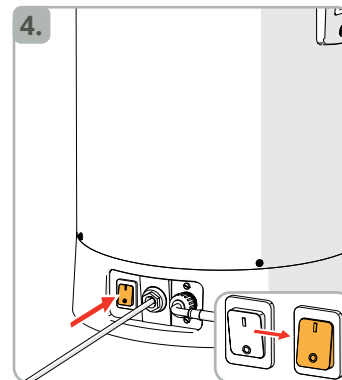
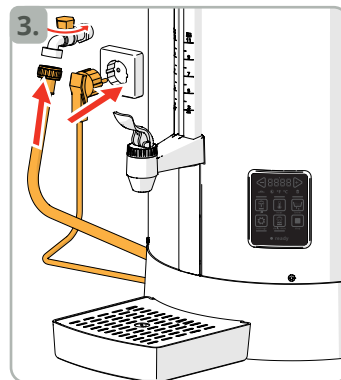
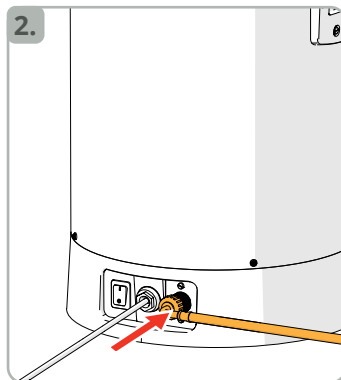
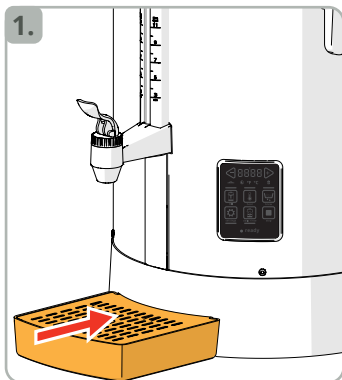

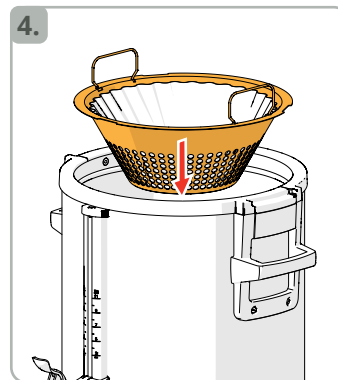
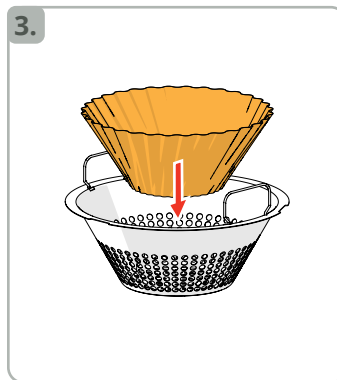
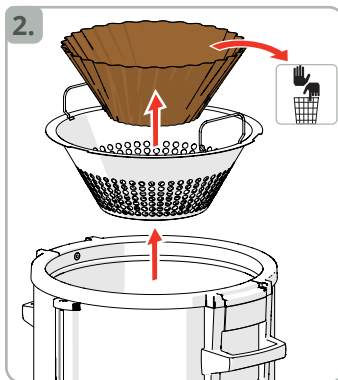
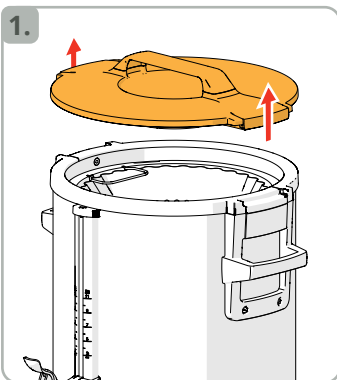

5. coffee grind size |  
Kaffeemahlgrad |  
taille de mouture du café |  
koffiemaling |  
dimensione di macinatura del caffè |  
tamaño del molido del café |  
tamanho da moagem do café |  
kaffens kornstørrelse |  
malningsgrad |  
rozmiar mielenia kawy |  
咖啡研磨粗細度 |  
قوةمقلا نحت م حح |  
размер помола кофе

recommended dosage |  
Dosierungsempfehlung |  
recommandation posologique |  
aanbevolen dosering |  
dosaggio consigliato |  
ecomendación de dosificación |  
recomendação de dosagem |  
anbefalt dosering |  
rekommenderad dosering |  
zalecane dawkowanie |  
建議劑量 |  
ادب یصوملا ةعرجل |  
рекомендации по дозировке

500 µm  
550 µm  
650 µm

50 g/l  
55 g/l  
60 g/l

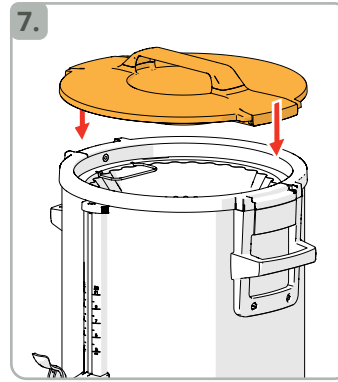
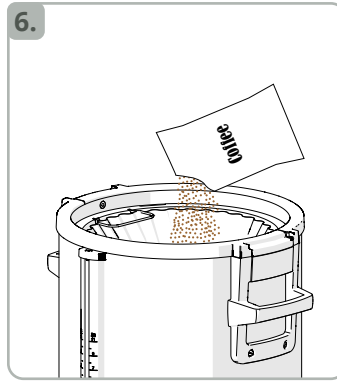

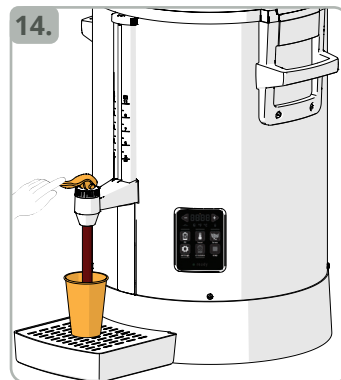
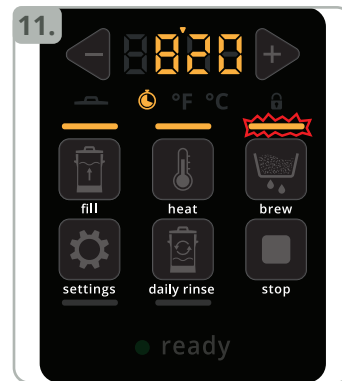
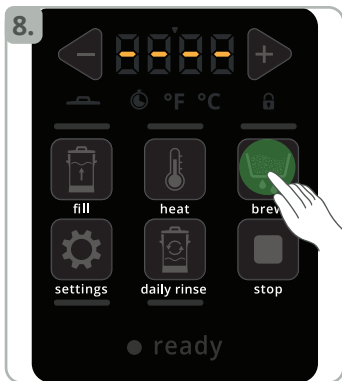



manual cleaning | manuelle Reinigung | nettoyage manuel | handmatige reiniging | pulizia manuale | limpeza manual | limpeza manual | manuelt rengjøring | manuelt rengöring | czyszczenie ręczne | 手動清潔 | يوديها فيظنتل | ручная очистка

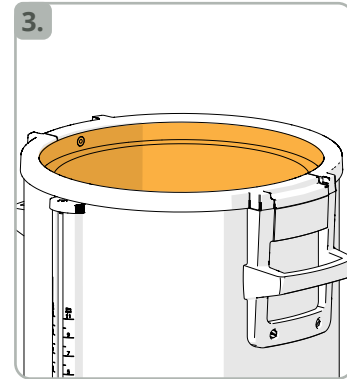
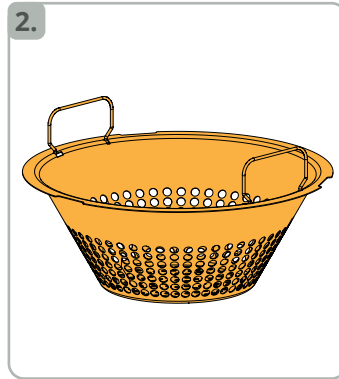
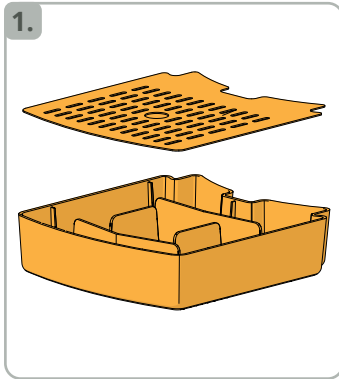

daily rinsing | tägliche Spülung | rinçage quotidien | dagelijks spoelen | risciacquo quotidiano | aclarado diario | enxaguamento diário | daglig skylling | daglig sköljning | codzienne płukanie | 每日沖洗 | يحوي فطش | ежедневное полоскание

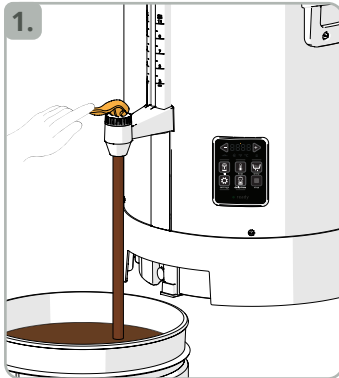

2. automatic filling or 4 L manual filling |  
 automatische Befüllung oder 4 L Handbefüllung |  
 remplissage automatique ou remplissage manuel de 4 L |  
 automatisch vullen of handmatig vullen van 4 liter |  
 riempimento automatico o riempimento manuale da 4 L |  
 llenado automático o manual de 4 L |  
 enchimento automático ou manual de 4 L |  
 automatisk påfylling eller manuell påfylling på 4 liter |  
 automatisk påfyllning eller manuell påfyllning av 4 liter |  
 automatyczne napełnianie lub ręczne napełnianie 4 L |  
 自動充填或 4 L 手動充填 |  
 رنل 4 ءعس ءيودي ءىبء وأ ءيكيءاموتوأ ءىبء |  
 автоматическая заправка или ручная заправка 4 л



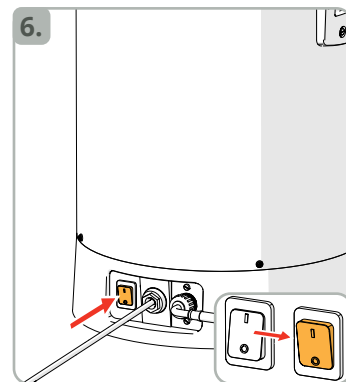
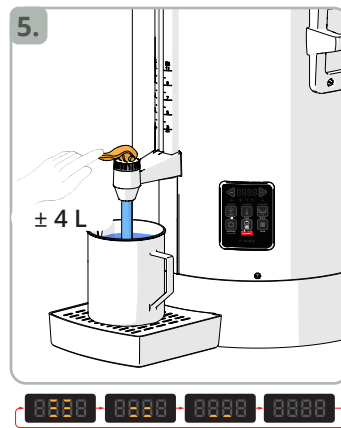
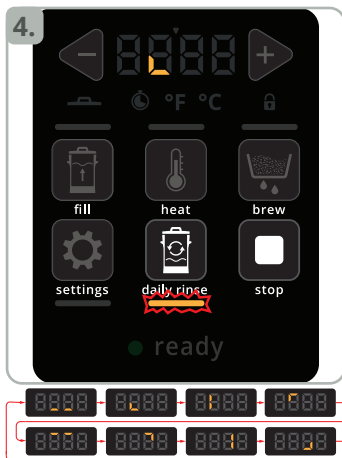

 semi-automatic cleaning | halb-automatische Reinigung | nettoyage semi-automatique | halfautomatische reinigung | pulizia semiautomatica | limpieza semi-automática | limpeza semi-automática | halvautomatisk rengjøring | halvautomatisk rengjøring | czyszczenie półautomatyczne | 半自動清潔 | يلى آههش فىظنت | полуавтоматическая очистка

 50 min

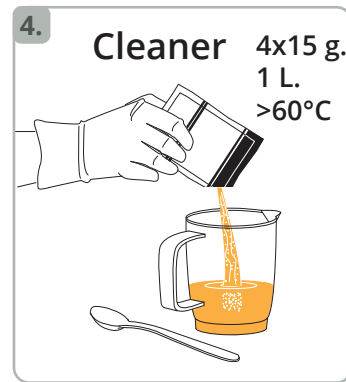
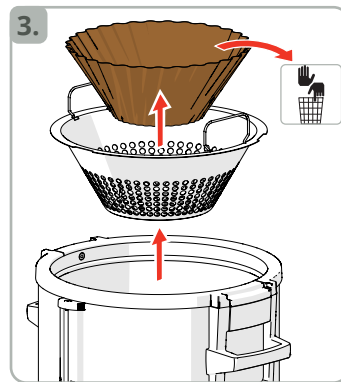
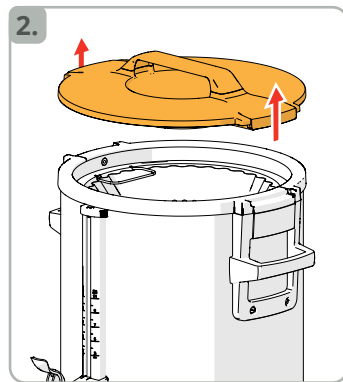
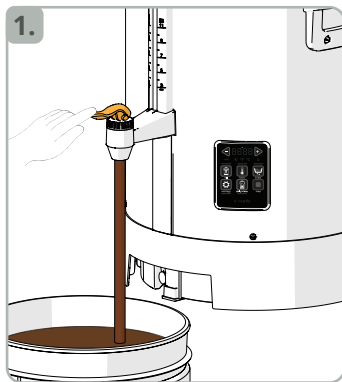

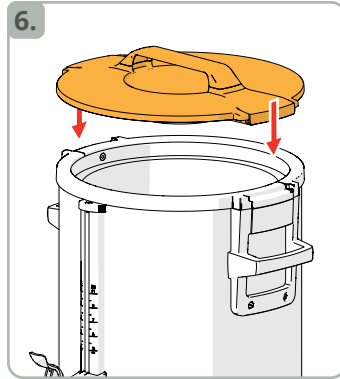
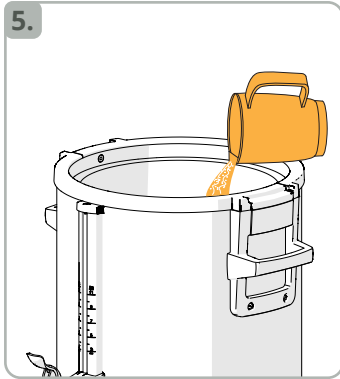

7. automatic filling or 10 L manual filling |  
 automatische Befüllung oder 10 L Handbefüllung |  
 remplissage automatique ou remplissage manuel de 10 L |  
 automatisch vullen of handmatig vullen van 10 liter |  
 riempimento automatico o riempimento manuale da 10 L |  
 llenado automático o manual de 10 L |  
 enchimento automático ou manual de 10 L |  
 automatisk påfylling eller manuell påfylling på 10 liter |  
 automatisk påfyllning eller manuell påfyllning av 10 liter |  
 automatyczne napełnianie lub ręczne napełnianie 10 L |  
 自動充填或 10 L 手動充填 |  
 رتل 10 عسع ؤيودي ؤئبع ؤا ؤئكيتاموت ؤا ؤئبع  
 автоматическая заправка или ручная заправка 10 л

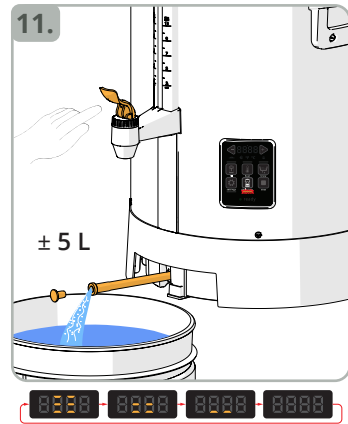
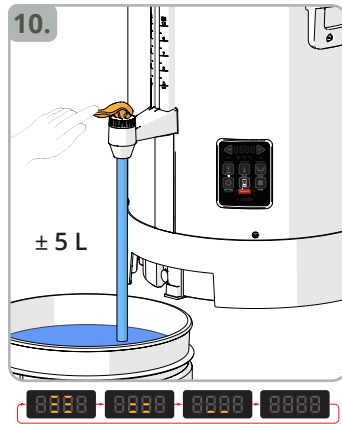

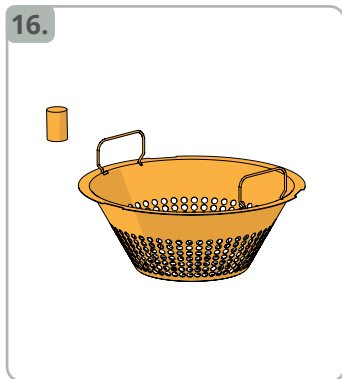
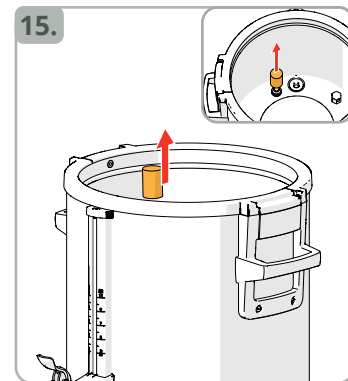
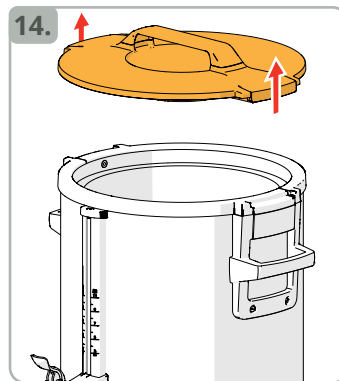
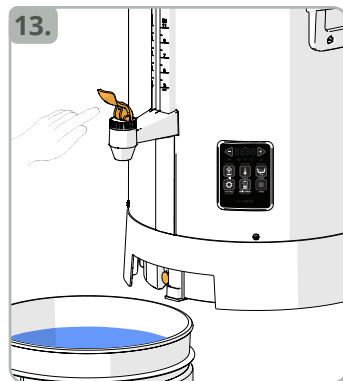
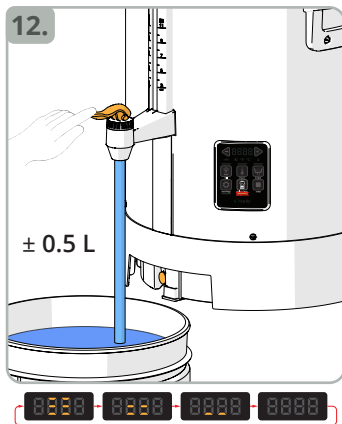

17. *stubborn dirt* | *hartnäckige Verschmutzung* | *salissures tenaces* | *hardnekkig vuil* | *sporczia ostinata* | *contaminación persistente* | *sujidade persistente* | *vanskelig smuss* | *svår borttagen smuts* | *trudne do usunięcia zabrudzenia* | 頑固汚漬 | 頑固汚漬 | 頑固汚漬 | 頑固汚漬

immerse basket and filter in cleaning solution for 30 minutes and brush clean |

Korb und Filter 30 Minuten lang in Reinigungslösung eintauchen und mit einer Bürste reinigen |

plongez le panier et le filtre dans la solution nettoyante pendant 30 minutes, puis brossez-les |

dompel het mandje en het filter 30 minuten onder in de reinigingsoplossing en borstel ze schoon |

immergere il cestello e il filtro nella soluzione detergente per 30 minuti e pulirli con una spazzola |

sumergir la cesta y el filtro en la solución limpiadora durante 30 minutos y cepillar |

mergulhe o cesto e o filtro na solução de limpeza durante 30 minutos e escove para limpar |

legg kurven og filteret i bløt i rengjøringsvæsken i 30 minutter, og børst dem rene |

Lägg ner korgen och filtret i rengöringsvätskan i 30 minuter och borsta dem rena |

zanurz kosz i filtr w roztworze czyszczącym na 30 minut, a następnie wyczyść szczotką |

將籃子和濾網浸泡於清潔溶液中30分鐘，並用刷子刷洗乾淨 |

داشرفلاب امهفبظننتب مؤو فؤقؤؤؤ 30 ءءمل فبفبظننتل لؤلؤم فبف ربتلفلاؤ ءلسلا رمؤا |

погрузите корзину и фильтр в чистящий раствор на 30 минут и очистите щеткой



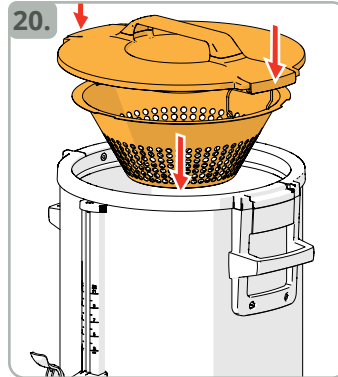
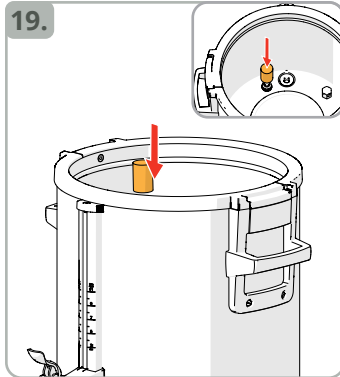
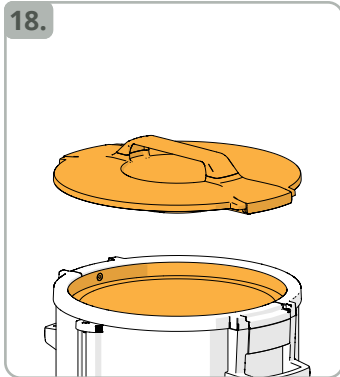

21. automatic filling or 4 L manual filling |  
 automatische Befüllung oder 4 L Handbefüllung |  
 remplissage automatique ou remplissage manuel de 4 L |  
 automatisch vullen of handmatig vullen van 4 liter |  
 riempimento automatico o riempimento manuale da 4 L |  
 llenado automático o manual de 4 L |  
 enchimento automático ou manual de 4 L |  
 automatisk påfylling eller manuell påfylling på 4 liter |  
 automatisk påfyllning eller manuell påfyllning av 4 liter |  
 automatyczne napełnianie lub ręczne napełnianie 4 L |  
 自動充填或 4 L 手動充填 |  
 رتل 4 ءحس ءيودي ءيىبعت وأ ءيكيىت اموتوأ ءيىبعت |  
 автоматическая заправка или ручная заправка 4 л

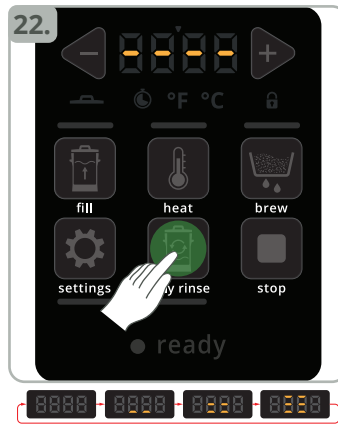

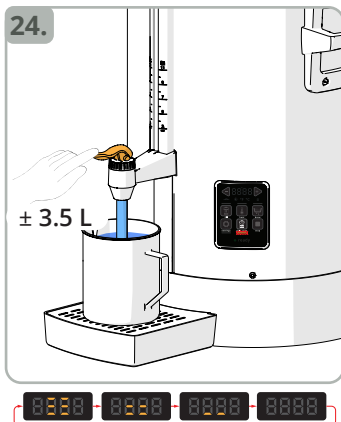

**!** *Note | Hinweis | Remarque | Opmerking | Nota | Nota |*  
*Observação | Merknad | Anmärkning | Uwaga | تظحالم | Примечание* **!**

After use, always replace the lid on the machine |  
Nach Gebrauch muss der Deckel immer wieder korrekt auf das Gerät aufgesetzt werden |  
Après utilisation, le couvercle doit toujours être remplacé correctement sur la machine |  
Plaats na gebruik altijd het deksel weer op het apparaat |  
Dopo l'uso, rimettere sempre il coperchio sulla macchina |  
Después de su uso, la tapa debe volver a colocarse correctamente en la máquina |  
Após o uso, a tampa deve ser sempre recolocada corretamente na máquina |  
Etter bruk må du alltid sette lokket på maskinen igjen |  
Sätt alltid tillbaka locket på maskinen efter användning |  
Po użyciu należy zawsze prawidłowo założyć pokrywę na urządzenie |  
使用後，務必將蓋子正確地放回機器上 |  
زاهجلا لى لى ع حي حصلا من الكم لى لى اعطغلا فداع! امئ اد ب جي ءم ادختس ال د ع ب |  
После использования крышку необходимо всегда правильно устанавливать на машину

# Brewing your coffee

S I N C E 1 9 4 8

The logo consists of three vertical red bars of varying heights on the left, followed by the text 'BRAVILOR' in a bold, black, sans-serif font, and 'BONAMAT' in a bold, black, sans-serif font below it.

**BRAVILOR**  
**BONAMAT**